



Owner's Manual and Instructions

Circulating Tent Heaters



MODELS	OUTPUT (kW)	FUEL
TS170	49.85	Available in either Propane Vapor Withdrawal or Natural Gas Configurations



Congratulations!

You have purchased the finest tent heater available.

Your new L.B. White heater incorporates the benefits from the most experienced manufacturer of heating products using state-of-the-art technology.

We, at L.B. White, **thank you** for your confidence in our products and welcome any suggestions or comments you may have...call us, at 608-783-5691.

ATTENTION ALL USERS

This heater has been designed and developed specifically for use as a direct-fired circulating heater for tent heating applications. The heater has been evaluated by Advantica Certification Services and found to conform to essential health and safety requirements as required by the Gas Appliance Directive, Low Voltage Directive, and Electromagnetic directive. If you are considering using this product for any application other than its intended use, then please contact your local agent, or contact L. B. White Co., Inc. in the U.S.A. at 608-783-5691.



Quality heaters you can count on.

W6636 L.B. White Rd., Onalaska, WI 54650 ■ (800) 345-7200 ■ (608) 783-5691 ■ (608) 783-6115, fax ■ info@lbwhite.com



GENERAL HAZARD WARNING

- Failure to comply with the precautions and instructions provided with this heater, can result in:
 - Death
 - Serious bodily injury or burns
 - Property damage or loss from fire or explosion
 - Asphyxiation due to lack of adequate air supply or carbon monoxide poisoning
 - Electrical shock
- Read this Owner's Manual before installing or using this product.
- Only properly-trained service people should repair or install this heater.
- Save this Owner's Manual for future use and reference.
- Owner's Manuals and replacement labels are available at no charge. For assistance, contact L.B. White at 608-783-5691.



WARNING

- Proper gas supply pressure must be provided to the inlet of the heater.
- Refer to the heater's dataplate for proper gas supply pressure.
- Gas pressure in excess of the maximum inlet pressure specified at the heater inlet can cause fires or explosions.
- Fires or explosions can lead to serious injury, death, or building damage.
- Gas pressure below the minimum inlet pressure specified at the heater inlet may cause improper combustion.
- Improper combustion can lead to asphyxiation or carbon monoxide poisoning and therefore serious injury or death to humans.



WARNING

Fire and Explosion Hazard

- Not for home or recreational vehicle use.
- Installation of this heater in a home or recreational vehicle may result in a fire or explosion.
- Fire or explosions can cause property damage or loss of fire.

FOR YOUR SAFETY

Do not store or use gasoline or other flammable vapors and liquids in the vicinity of this or any other heater.

FOR YOUR SAFETY

- If you smell gas:
1. Open windows.
 2. Don't touch electrical switches.
 3. Extinguish any open flame.
 4. Immediately call your gas supplier.



WARNING

Fire and Explosion Hazard

- Keep solid combustibles a safe distance away from the heater.
- Solid combustibles include wood or paper products.
- Do not use the heater in spaces which contain or may contain volatile or airborne combustibles.
- Volatile or airborne combustibles include gasoline, solvents, paint thinner, dust particles or unknown chemicals.
- Failure to follow these instructions may result in a fire or explosion.
- Fire or explosions can lead to property damage, personal injury or loss of life.



<u>SECTION</u>	<u>PAGE</u>
General Information	3
Heater Specifications	4
Fuel Information for Country of Destination	5
Safety Precautions	6
Installation Instructions	
General	8
Heater Sizing Guidelines	10
Cylinder Selection	10
Handle Assembly	11
Wheel Assembly	11
Leg Assembly	11
Hose Hanger and Regulator Storage Bracket Assembly	12
Hose and Regulator Assembly	12
Duct Installation	13
End Diffuser Assembly	14
Connecting Regulator to Propane Gas Supply Cylinder	14
Start-Up Instructions	15
Shut-Down Instructions	15
Cleaning Instructions	16
Maintenance Instructions	16
Service Instructions	
Motor and Fan Wheel Assembly	17
Air Proving Switch with Paddle	17
Igniter and Flame Sensor	18
Fuse Holder and Fuse	18
Gas Pressure Checks	19
High Limit Switches	20
Burner Orifice and Gas Control Valve	20
Troubleshooting Guide	21
Electrical Connection and Ladder Diagram	26
Heater Component Function	27
Parts Identification	
Parts Schematic	28
Parts List	29
Warranty Policy	30
Replacement Parts and Service	30

General Information

This Owner's Manual includes information for all options and accessories commonly used on this heater.

When calling for technical service assistance, or for other specific information, always have model number, configuration number and serial number available. This information is contained on the dataplate. The dataplate is located on the exterior of the burner end door.

This manual will instruct you in the operation and care of your unit. Have your qualified installer review this manual with you so that you fully understand the heater and how it functions.

The gas supply line installation, installation of the heater, and repair and servicing of the heater requires continuing expert training and knowledge of gas heaters and should not be attempted by anyone who is not so qualified. See page 6 for definition of the necessary qualifications.

Contact your local L.B. White distributor or the L.B. White Co., Inc. for assistance, or if you have any questions about the use of the equipment or its application.

The L.B. White Co., Inc. has a policy of continuous product improvement. It reserves the right to change specifications and design without notice.

Heater Specifications

		Model
SPECIFICATIONS	TS170	
Maximum Input (kW)	49.85	
Ventilation Air Required to Support Combustion (m ³ /hr)	1870	
Burner Manifold Pressure Relative to Gas Category (mbar)	PROPANE	25 I _{3P} 20/25 I _{3B/P}
	NATURAL GAS	9 I _{2E} , I _{2E(S)B} , I _{2H} 13.5 I _{2L} 9/13 I _{2Er}
	Ball Bearing	
	248 Watts 1100 RPM	
Motor Characteristics		
Electrical Rating	IP14B	
Electrical Supply (Volts/Hz/Phase)	220-240/50/1	
Amp Draw	STARTING	8.0
	CONTINUOUS OPERATION	2.5
Minimum Safe Distances From Nearest Combustible Materials	TOP	.3 m
	SIDES	.3 m
	BACK	.3 m
	BLOWER OUTLET	Combustible Materials - 1.83 m Propane Gas Cylinder - 6.10 m
	GAS SUPPLY	Propane Gas Supply – 1.83 m Natural Gas Supply – N/A
Minimum Ambient Temperature in Which Heater May be Operated	-28° C	
Dimensions L x W x H(cm)	78 x 46 x 72	
Air Delivery Temperature at a 1.5 Meter Arc from Blower Outlet of Heater	40° C	

FUEL INFORMATION FOR COUNTRY OF DESTINATION

Propane Gas		
Destination Countries	Gas Category & Pressure (mbar)	Rate (kg/hr)
HU & NL	I _{3P} (30)	3.57
PL	I _{3P} (36)	
BE, CH, CZ, ES, FR GB, IE, PT, SI & SK	I _{3P} (37)	
BE, CH, DE, ES & NL	I _{3P} (50)	
CY, CZ, DK, EE, FI, GR, HU, IT, LT, LV, MT, NO & SE	I _{3B/P} (30)	(Butane) 3.62
		(Propane) 3.57

Natural Gas		
Destination Countries	Gas Category & Pressure (mbar)	Rate (m³/Hr)
AT, CH, CZ, DK, EE, ES, FI, GB, GR, IE, IT, LT, LV, NO, PT SE, SI, SK & TR	I _{2H} (20)	4.81
DE, LU & PL	I _{2E} (20)	
BE	I _{2E(S)B} (20)	
FR	I _{2Er} (20/25)	(G-20) 4.81
		(G-25) 5.51
NL	I _{2L} (25)	5.51

Safety Precautions

WARNING

Asphyxiation Hazard

- This heater is intended for heating of tents with temporary human occupancy. Do not use this heater for heating human living quarters.
- Do not use in unventilated areas.
- The flow of combustion and ventilation air must not be obstructed.
- Proper ventilation air must be provided to support the combustion air requirements of the heater being used.
- Refer to the specification section of the heater's Owner's Manual, heater dataplate, or contact the L.B. White Company to determine combustion air ventilation requirements of the heater.
- Lack of proper ventilation air will lead to improper combustion.
- Improper combustion can lead to carbon monoxide poisoning in humans leading to serious injury or death. Symptoms of carbon monoxide poisoning can include headaches, dizziness and difficulty in breathing.

FUEL GAS ODOR

LP gas and natural gas have man-made odorants added specifically for detection of fuel gas leaks.

If a gas leak occurs, you should be able to smell the fuel gas.

THAT'S YOUR SIGNAL TO GO INTO IMMEDIATE ACTION!

- Do not take any action that could ignite the fuel gas. Do not operate any electrical switches. Do not pull any power supply or extension cords. Do not light matches or any other source of flame. Do not use your telephone.
- Get everyone out of the building and away from the area immediately.
- Close all propane (LP) gas tank or cylinder fuel supply valves, or the main fuel supply valve located at the meter if you use natural gas.
- Propane (LP) gas is heavier than air and may settle in low areas. When you have reason to suspect a propane leak, keep out of all low areas.
- Natural gas is lighter than air and can collect around rafters or ceilings.
- Use your neighbor's phone and call your fuel gas supplier and your fire department. Do not re-enter the building or area.
- Stay out of the building and away from the area until declared safe by the firefighters and your fuel gas supplier.
- **FINALLY**, let the fuel gas service person and the firefighters check for escaped gas. Have them air out the building and area before you return. Properly trained service people must repair the leak, check for further leakages, and then relight the appliance for you.

ODOR FADING -- NO ODOR DETECTED

- Some people cannot smell well. Some people cannot smell the odor of the man-made chemical added to propane (LP) or natural gas. You must determine if you can smell the odorant in these fuel gases.
- Learn to recognize the odor of propane (LP) gas and natural gas. Local propane (LP) gas dealers and your local natural gas supplier (utility) will be more than happy to give you a "scratch and sniff" pamphlet. Use it to become familiar with the fuel gas odor.
- Smoking can decrease your ability to smell. Being around an odor for a period of time can affect your sensitivity to that particular odor.
- The odorant in propane (LP) gas and natural gas is colorless and the intensity of its odor can fade under some circumstances.
- If there is an underground leak, the movement of gas through the soil can filter the odorant.
- Propane (LP) gas odor may differ in intensity at different levels. Since propane (LP) gas is heavier than air, there may be more odor at lower levels.
- **Always be sensitive to the slightest gas odor.** If you continue to detect any gas odor, no matter how small, treat it as a serious leak. Immediately go into action as discussed previously.

ATTENTION -- CRITICAL POINTS TO REMEMBER!

- Propane (LP) gas and natural gas have a distinctive odor. Learn to recognize these odors. (Reference "Fuel Gas Odor" and "Odor Fading" sections above.)
- Even if you are not properly trained in the service and repair of the heater, ALWAYS be consciously aware of the odors of propane (LP) gas and natural gas.
- If you have not been properly trained in repair and service of propane (LP) gas and natural gas fueled heaters, then do not attempt to light heater, perform service or repairs, or make any adjustments to the heater on propane (LP) gas or natural gas fuel system.
- A periodic "sniff test" around the heater or at the heater's joints; i.e. hose, connections, etc., is a good safety practice under any conditions. If you smell even a small amount of gas, CONTACT YOUR FUEL GAS SUPPLIER IMMEDIATELY. DO NOT WAIT!

Safety Precautions

1. Do not attempt to install, repair, or service this heater or the gas supply line unless you have continuing expert training and knowledge of gas heaters.

Qualifications for service and installation of this equipment are as follows:

- a. To be a qualified gas heater service person, you must have sufficient training and experience to handle all aspects of gas-fired heater installation, service and repair. This includes the task of installation, troubleshooting, replacement of defective parts and testing of the heater. You must be able to place the heater into a continuing safe and normal operating condition. You must completely familiarize yourself with each model heater by reading and complying with the safety instructions, labels, Owner's Manual, etc., that is provided with each heater.
 - b. To be a qualified gas installation person, you must have sufficient training and experience to handle all aspects of installing, repairing and altering gas lines, including selecting and installing the proper equipment, and selecting proper pipe and tank size to be used. This must be done in accordance with all local, regional and national codes as well as the manufacturer's requirements.
2. All installations and applications of L.B. White heaters must meet all relevant local, regional and national codes. Included are L.P. gas, natural gas, electrical, and safety codes. Your local fuel gas supplier, a local licensed electrician, the local fire department or similar government agencies, or your insurance agent can help you determine code requirements.
 3. Do not move, handle, or service heater while in operation or connected to a power or fuel supply.
 4. Do not wash the interior or exterior of the heater. Use only compressed air, a soft brush or dry cloth to clean the interior or exterior of the heater and its components.
 5. For safety, this heater is equipped with manual reset high-limit switches and an air flow switch. Never operate this heater with any safety device that has been bypassed. Do not operate this heater unless all of these features are fully functioning.
 6. Do not operate the heater with its door open or panel removed.
 7. The heater must be located at least 1.83 m. from any propane gas container.
 8. Do not block air intakes or discharge outlets of the heater. Doing so may cause improper combustion or damage to heater components leading to property damage.
 9. The hose assembly shall be visually inspected prior to each use of the heater. If it is evident there is excessive abrasion or wear, or if the hose is cut, it must be replaced prior to the heater being put into operation. The hose assembly shall be protected from traffic, building materials, and contact with hot surfaces during use. The hose assembly shall be that specified by the manufacturer. See parts list.
 10. Check for gas leaks and proper function upon heater installation or when relocating.
 11. This heater should be inspected for proper operation by a qualified service person upon installation and at least annually.
 12. Always turn off the gas supply to the heater if the heater is not going to be used.
 13. This heater is wired for a three-wire electrical system. There is a hot lead, neutral lead, and a ground lead. The heater may or may not incorporate a plug in the power cord on the heater and the plug may or may not incorporate a pin for the ground wire. In any case, the heater must be properly connected into a grounded electrical supply using the ground lead in the power cord. Failure to use a properly grounded electrical supply can result in electrical shock, personal injury, or death.
 14. Direct spark ignition heaters will make up to three trials for ignition. If ignition is not achieved after the third trial, the control system will "lock out" the gas control valve. If gas is smelled after system lock out has occurred, immediately close all fuel supply valves. Do not relight until you are sure that all gas that may have accumulated has cleared away. In any event, do not relight for at least 5 minutes.
 15. Installations not using the gas hose supplied with this appliance must connect dimensionally using BS1387 Medium Duty Galvanized Steel Tube. (Aluminum piping or tubing shall not be used.) Copper tubing when used for conveying natural gas, shall be internally tinned or equivalently treated to resist sulphur.
 16. The minimum gas cylinder size shall be a 47 KG cylinder.
 17. The hot air discharge of the heater and its ductwork shall not be directed toward any propane gas cylinder within 6.10 m. of the air discharge.
 18. During storage, the connection between the L.P. gas supply cylinder and the heater must be disconnected. The cylinder(s) must be moved from the heater and stored in accordance with local codes.

Installation Instructions

GENERAL



WARNING

Fire and Explosion Hazard

Can cause proper damage, severe injury or death.

- Disconnect power supply before wiring to prevent electrical shock or equipment damage.
- To avoid dangerous accumulation of fuel gas, turn off gas supply at the appliance service valve before starting installation, and perform gas leak test after completion of installation.



WARNING

Fire and Explosion Hazard

- Do not use open flame (matches, torches, candles, etc.) in checking for gas leaks.
- Use only approved leak detectors.
- Failure to follow this warning can lead to fires or explosions.
- Fires or explosions can lead to property damage, personal injury or loss of life.

1. Read all safety precautions and follow L. B. White recommendations when installing this heater. If during the installation or relocating of heater, you suspect that a part is damaged or defective, call a qualified service agency for repair or replacement.
2. Insure that all accessories that ship within the heater have been removed from inside of heater and installed. This pertains to gas hose, regulators, etc.
3. Make sure the heater is properly positioned before use. Observe and obey all minimum safe distances of the heater to the nearest combustible materials. Minimum safe distances are given on the heater dataplate and on page 4 of this manual.
4. The heater is designed for either indoor or outdoor use. For outdoor application, the heater is approved for use with a .3 meter diameter by 4 meter long flexible duct and air diffuser as supplied by the L.B. White Co. The heater shall not be used with any other ducting or ductwork.
5. Heaters used in the vicinity of combustible tarpaulins, canvas, plastic wind barriers, or similar coverings and materials shall be located at least 3 m from the coverings. The coverings shall be securely fastened to prevent ignition or upsetting of the heater due to wind action on the covering or other materials.
6. The heater shall be located so that rain, ice, or snow drainage from the structure does not affect heater operation. If the heater is installed outside, it must be installed above any pooled or standing water. If

the heater is located on the ground, a surrounding trench is recommended to drain any rain, ice or snow away from the heater.

7. The heater must be installed on a flat, horizontal surface.
8. Locate the heater so as to protect it from tipover or accidental movement.
9. The heater must be installed so as not to interfere with or obstruct normal exits, emergency exits, doors and walkways.
10. Railing, fencing or suitable substitute materials should be used as needed to isolate the heater from people using and visiting the temporary structure.
11. Do not use the heater equipment area for storage of any other materials.
12. The ground and surrounding terrain must be cleared of any combustible vegetation and other combustible materials.
13. Protect any electrical wiring and gas hoses with a shield device of suitable nature to protect both from equipment and people traffic.
14. Make sure that gas regulator is appropriate for the fuel source; LP-Gas or natural gas. The regulator must be properly connected to the LP-Gas cylinder or natural gas supply to assure that gas pressure at the inlet to the gas valve is regulated within the range specified on the dataplate. The heater's gas regulator (with pressure relief valve) should be installed outside of the tent. Any regulators within the tent must be properly vented to the outside. Local, regional and national codes always apply to regulator installation. Contact your gas supplier or local L.B. White agent if there are any questions.
15. Check all connections for gas leaks using approved gas leak detectors. Gas leak testing is performed as follows:



WARNING

Fire and Explosion Hazard

- Do not use open flame (matches, torches, candles, etc.) in checking for gas leaks.
- Use only approved leak detectors.
- Failure to follow this warning can lead to fires or explosions.
- Fires or explosions can lead to property damage, personal injury or loss of life.

-
- Check all pipe connections, hose connections, fittings and adapters upstream of the gas control with approved gas leak detectors.
 - In the event a gas leak is detected, check the components involved for cleanliness and proper application of pipe compound before further tightening.
 - Tighten the gas connections as necessary to stop the leak.
 - After all connections are checked and any leaks are stopped, turn on the main burner.
 - Stand clear while the main burner ignites to prevent injury caused from hidden leaks that could cause flashback.
 - With the main burner in operation, check all connections, hose connections, fittings and joints as well as the gas control valve inlet and outlet connections with approved gas leak detectors.
 - If a leak is detected, check the components involved for cleanliness in the thread areas and proper application of pipe compound before further tightening.
 - Tighten the gas connection as necessary to stop the leak.
- If necessary, replace the parts or components involved if the leak cannot be stopped.
 - Ensure all gas leaks have been identified and repaired before proceeding.
16. A qualified service agency must check for proper operating gas pressure upon installation of the heater.
 17. Light according to instructions on heater or within owner's manual.
 18. This heater can be configured for use with either L.P. gas vapor withdrawal or natural gas. Consult the dataplate, located on the exterior of the burner end door for the gas type of the specific heater. Do not use the heater in an L.P. gas liquid withdrawal system or application. If you are in doubt, contact your local agent or the L.B. White Co., Inc.
 19. Take time to understand how to operate and maintain the heater by using this Owner's Manual. Make sure you know how to shut off the gas supply to the heater. Contact your fuel gas supplier if you have any questions.
 20. Any defects found in performing any of the service or maintenance procedures must be eliminated and defective parts replaced immediately. The heater must be retested by a properly qualified service person before placing the heater back into use.

HEATER SIZING GUIDELINES

1. Multiply tent length x width x height = Cubic Meters (A).
2. Multiply (A) x .133 x 35 = (B).
3. Subtract outdoor temperature from desired indoor temperature = (C).
4. (B) x (C) ÷ 2 = Heat Requirements in Watts (D).
5. (D) ÷ 1,000 = Heat Requirements in KW.

EXAMPLE:

1. Tent Length (15 meters) x width (15 meters) x height (4 meters) = 900 cubic meters (A).
2. 900 (A) x .133 x 35 = 4190 (B).
3. 20° C. (Desired Temperature) - 0° C. (Outdoor Temperature) = 20° C. (C).
4. 4190 (B) x 20 (C) ÷ 2 = 41,900 Watts (D).
5. (D) 41,900 ÷ 1,000 = 41.9 KW.

Use one TS170 heater.

CYLINDER SELECTION

The amount of vaporized propane gas available from the cylinders will vary depending upon:

- The amount of liquid propane in the cylinder(s).
- The surrounding air temperature of the cylinder(s).

Since less gas is vaporized at lower temperatures, two or more 47 KG cylinders may be needed in colder weather. Your local propane gas dealer will help you select the proper supply system.

The following table shows the minimum number of 47 KG cylinders needed to run the heater.

Number of Cylinders Required at Various Temperatures

Model	20° C	15° C	10° C	5° C	0° C	-10° C
TS170	2	2	2	2	3	3

The diagram at right shows a supply time versus temperature comparison. It is based upon initial use of full, 47 KG cylinders and a heat load of 29.3 KW at continuous draw. Notice that one 47 KG cylinder may be used for about 3 hours maximum operating time when at 16° C. But, as temperature drops, so does the amount of time that the cylinder is capable of supplying the vapor necessary to feed the heater. Looking at 0° C. scale, you can see that a 47 KG cylinder is only capable of supplying the full heat load for one hour.

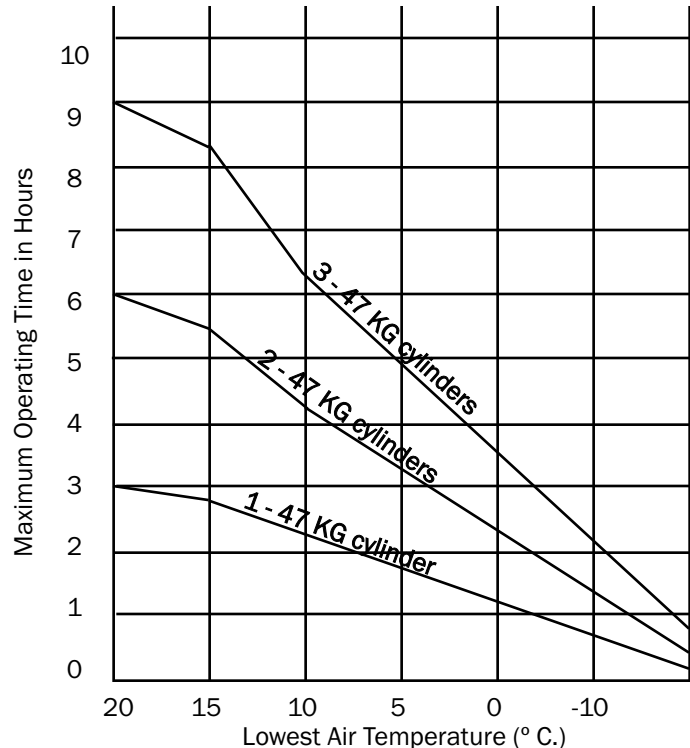

- Have your LP-gas supplier resize your installation from cylinders to a larger capacity tank if requirements are above three 47 KG cylinders capacity.
- The sizing, delivery, set up, and refilling of all L.P. gas supply containers must only be done by a qualified, properly trained, L.P. gas installation person.

SLIDING HANDLE ASSEMBLY

The Premier 170 is equipped with sliding handles for convenient wheel-barrow style mobility. Sliding handles are pre-assembled and installed on the heater case. For shipping purposes, the handles are turned from the required operating position.

1. Remove the sliding handles by grasping the free end and pulling the handle completely out of the handle bracket.
2. Align the snap button on the end of the handle with the retaining hole in the handle bracket.
3. Insert the end of the handle into the handle bracket and depress the snap-button.
4. Slide in the handle and depress the snap-button as necessary until the handle is locked in the fully retracted position.

FIG. 1

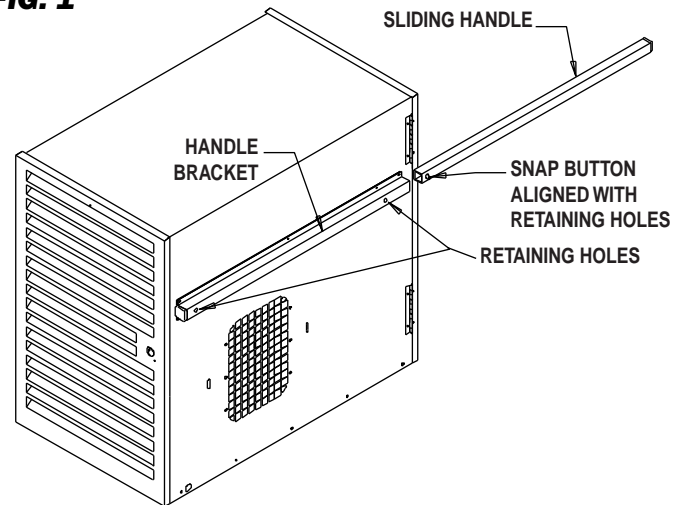

WHEEL ASSEMBLY

1. Refer to Fig. 2 for wheel assembly.
2. Ensure that the slots in wheels are facing outward before installing retainer caps onto shaft.

FIG. 2

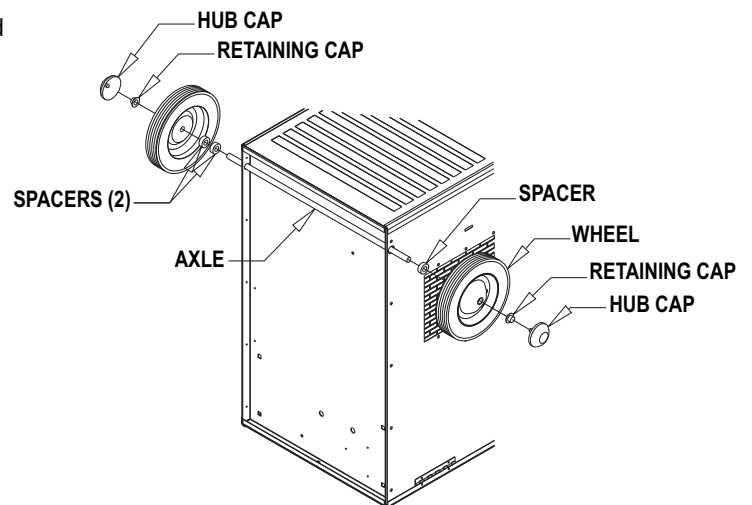

LEG ASSEMBLY

1. Align the support leg channel to the four cage nuts on underside of base. See Fig. 3.
2. Mount the support using four 1/2 in. bolts and lockwashers. Tighten securely.

FIG. 3

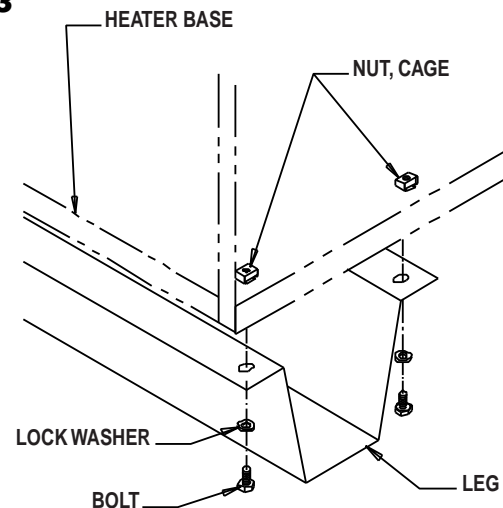

HOSE HANGER & REGULATOR STORAGE BRACKET ASSEMBLY

HOSE HANGER ASSEMBLY:

1. Align wire hose hanger to cage nuts on back of heater.
2. Mount the hanger using the 1/4-20 x 3/4 in. bolts and 1/4 in. flat washers. Tighten securely. See Fig. 4.

REGULATOR STORAGE BRACKET ASSEMBLY:

1. Align regulator storage bracket to the two 1/8 in. diameter holes on heater case back.
2. Mount the storage bracket to the case using the two 3/8 in. hex head screws at this point. Tighten securely.

FIG. 4

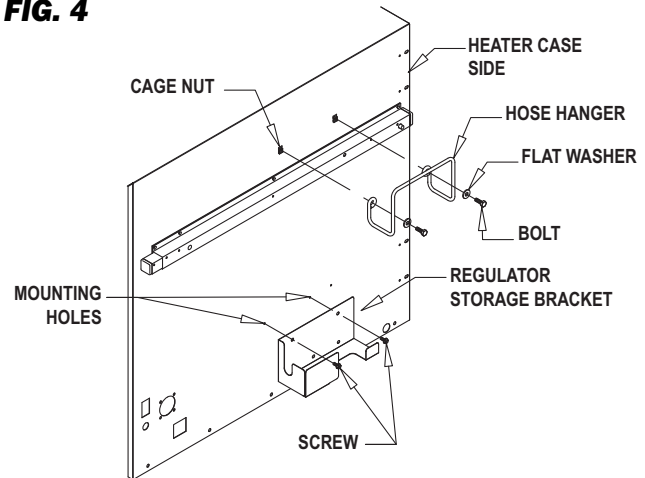

HOSE & REGULATOR ASSEMBLY (Accessory)

1. Use only pipe thread compound resistant to propane and natural gas.
2. Apply a moderate amount of pipe compound to pipe threads of hose adapter. Thread hose adapter into adapter at heater gas inlet and tighten securely. See Fig. 5.
3. Connect hose to hose adapter at heater and to adapter at gas regulator outlet. Tighten hose nuts securely.
4. Open fuel supply and check for gas leaks with approved leak detectors.
5. Start the heater and check for proper operation and gas leaks.
6. When storing, coil the hose and hang over the hose hanger. Store the regulator within the storage bracket.

FIG. 5

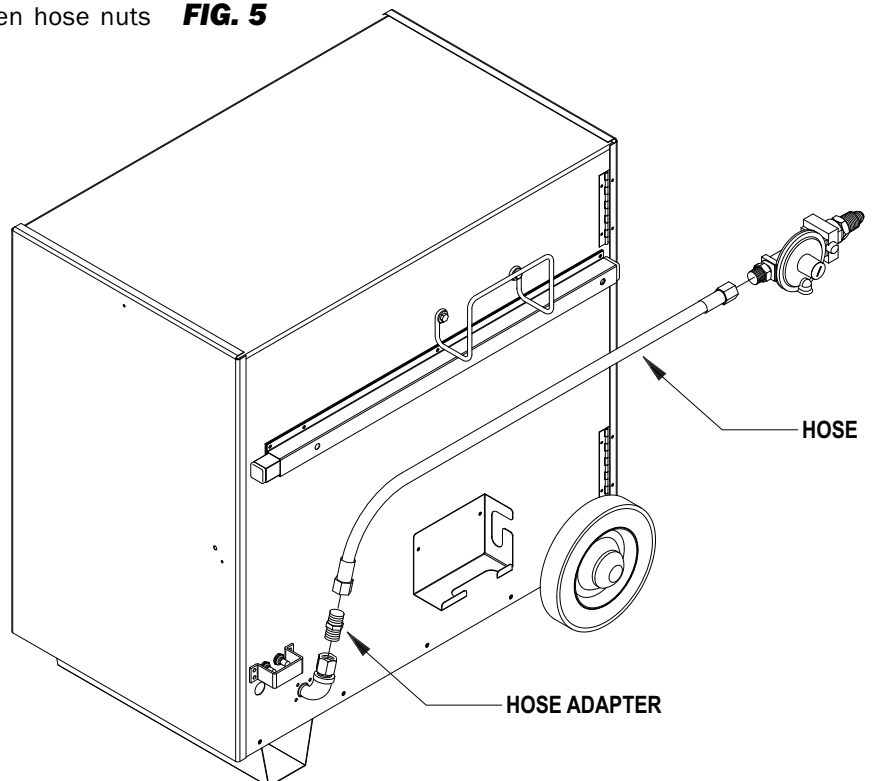

DUCT KIT ASSEMBLY
Accessory Part # 08978

1. Extend duct kit to 3.65 m. length.
2. Insert tabs on adapter into slots at blower outlet of heater. See Fig. 6. Push down to secure in place. See below typical installation of heater located to exterior of tent.

FIG. 6

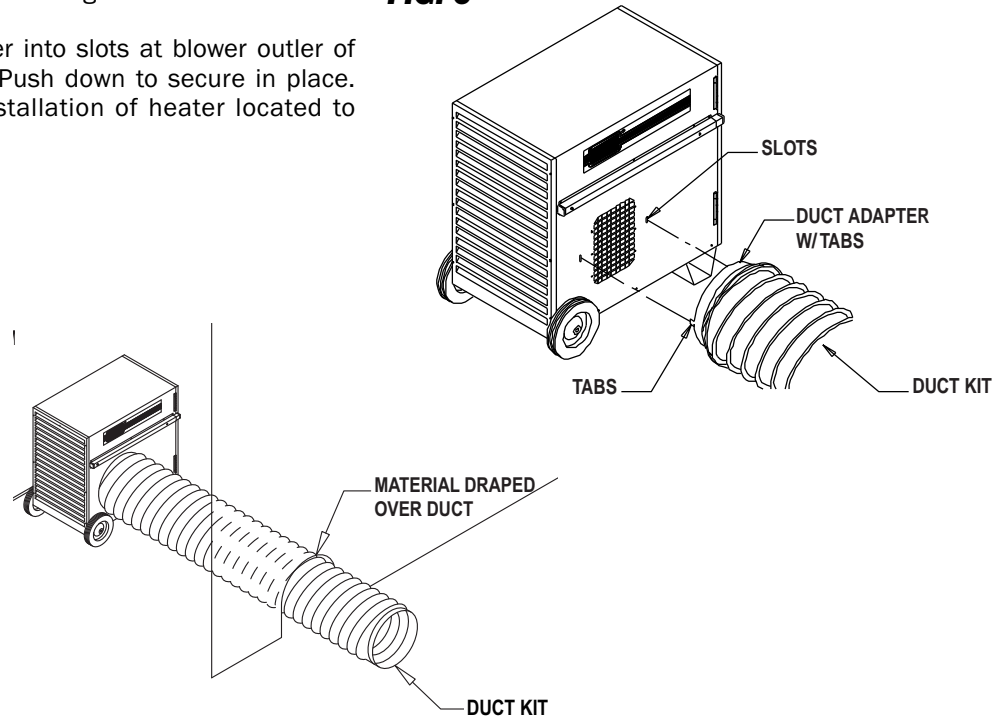

UNIT DIFFUSER ASSEMBLY
Accessory Part # 09396

1. Insert the tabs of the diffuser into the vertical slots at the blower outlet. Push down on diffuser to secure into place. See Fig. 7.
2. Tent side wall material may be layed within channel of the diffuser to give a finished look to the installation. See below for typical installation.

FIG. 7

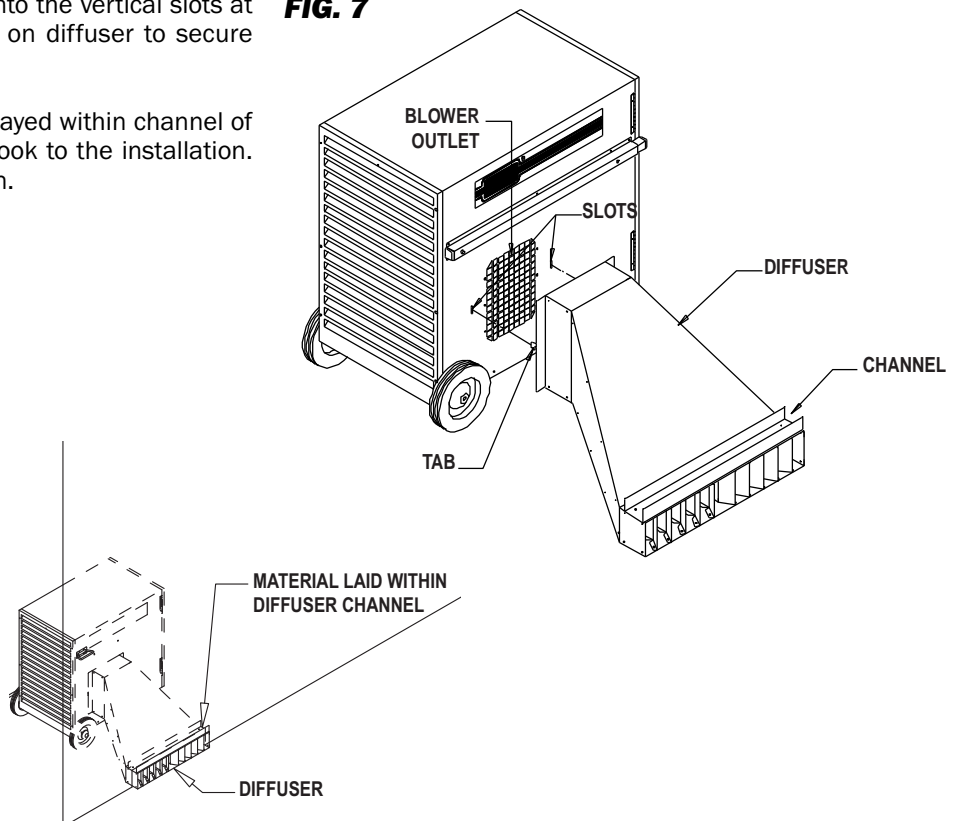

END DIFFUSER ASSEMBLY

Accessory Part # 21177

1. Insert collar into duct. Tabs of collar must be facing away from duct. See Fig. 8.
2. Wrap the duct clamp around duct and collar. Saddle of clamp lays over duct coil. Connect clamp ends together and tighten securely. See Fig. 8.
3. Insert tabs of collar into slots at air inlet of diffuser. Push down to lock in place.
4. Tent side wall material may be layed within channel of the diffuser to give a finished look to the installation. See Fig. 9 for typical installation.

FIG. 8

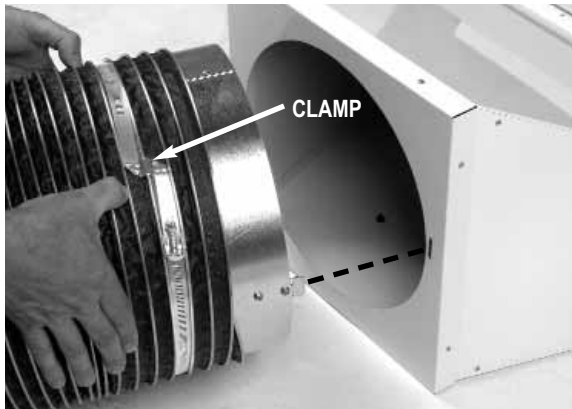
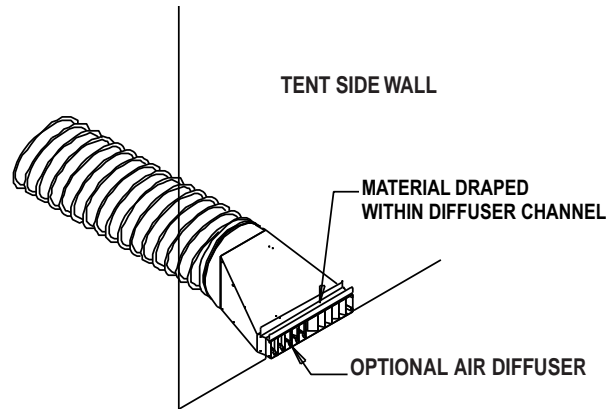

FIG. 9



CONNECTING REGULATOR TO PROPANE GAS

(Accessory)

ATTENTION

- Only use the regulator supplied with the heater.
- The heater must be regulated at all times for proper operation.

1. Remove the protective cap from the POL assembly, but do not discard it. Insert POL stem into the valve on the cylinder. Thread the nut counterclockwise into the tank valve. Tighten securely with a wrench. See Fig. 10.
2. Slowly open the cylinder valve. This will prevent lock-up of the excess flow valve built within POL stem.
3. Check all connections with approved leak detector. Do NOT use flame to check for leaks. A fire or explosion may result.
4. When storing or transporting the heater, ensure the cap is pushed back onto the POL fitting. This will protect the fitting from nicks or other damage and prevent the entry of moisture.

FIG. 10

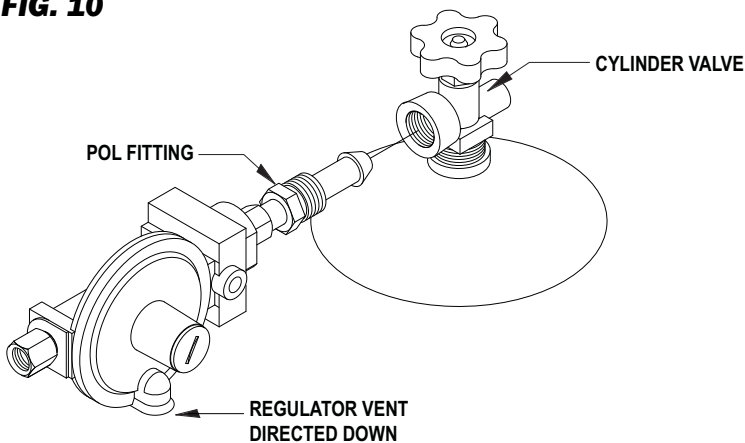

Start-Up Instructions

Follow steps 1 - 7 on initial start-up after heater installation by a qualified gas heater service person. For normal start-up, set thermostat above room temperature. The heater will start.

1. Open all manual fuel supply valves and check for gas leaks using approved leak detectors.
2. Connect the electrical cord to an approved electrical outlet.
3. Set the thermostat to desired room temperature.
4. A selector switch is located on the back of the heater. The selector switch allows you to either heat or ventilate (no heat). The switch positions are as shown in Fig. 11.

FIG. 11

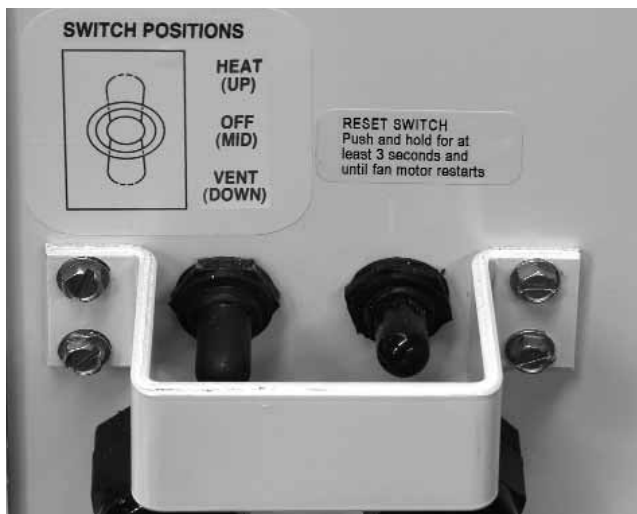

When the selector switch is set to Heat, the heater will cycle on and off based upon setting of the thermostat. To use the heater for ventilating, position the selector switch to Vent. With the switch in this position, the fan motor will operate continually. The thermostat will not cycle the heater, nor will the burner ignite.

5. This heater includes a direct spark ignition (DSI) control module for purposes of controlling the timing of the ignition process of the heater as well as monitoring of the safety functions. The DSI module is located at the burner end of the heater. Refer to the troubleshooting guide within this Owner's Manual if equipment malfunction occurs. Only qualified and properly trained personnel shall service or repair the heater.
6. On a call for heat, the motor will start up and run for five (5) seconds prior to ignition trial. This pre-purge is a safety feature and a normal operational characteristic. After five (5) seconds the igniter will spark until burner flame is detected by the control module.

NOTE: It is normal for air to be trapped in the gas hose on new installations. You may have to attempt more than one trial for ignition before the air is finally purged from the line and ignition takes place.

7. The ignition control will make three trials for ignition. If ignition is not achieved, the controller will shut the heater down. The ignition control must be reset. Push and hold the reset switch for at least 3 seconds and until fan motor restarts. See Fig. 11.
8. Do not exceed the input rating stamped on the dataplate of the heater. Do not exceed the burner manifold pressure stated on the dataplate. Do not use an orifice size different than specified for the specific input rating of this heater, fuel type configuration and altitude.

Shut-Down Instructions

1. For normal shutdown (when further use is anticipated), position the selector switch to Off and the thermostat to off or no heat.
2. To properly shut down the heater for service, maintenance, or relocation:
 - a. Position the selector switch to Off and disconnect the heater's electrical supply.
 - b. Close the gas supply valve(s) at gas source.
 - c. Disconnect heater's gas pressure regulator from gas source. A minimal amount of gas trapped in the gas hose will escape. This is normal and will not cause an unsafe condition.

Cleaning Instructions



WARNING Fire, Burn, and Explosion Hazard

- This heater contains electrical and mechanical components in the gas management, safety and airflow systems.
- Such components may become inoperative or fail due to dust, dirt, wear, and aging.
- Periodic cleaning and inspection as well as proper maintenance are essential to avoid serious injury or property damage.

1. Before cleaning, shut off all gas supply valves and disconnect the electrical supply.
2. The heater should have dirt or dust removed periodically:
 - a. After each use, give the heater a general cleaning using compressed air, a soft brush or dry rag on its interior and exterior.
 - b. At least once a year, give the heater a thorough cleaning. At this time, remove the fan and motor assembly and brush or blow off the fan wheel, giving attention to the individual fan blades. Dust off the motor case to prevent the motor from overheating and shutting the heater down. Ensure the burner air inlet venturi ports and the throat of the casting are free of dust accumulation and the area between the heat chamber top and inside case is also free of dust. The igniter should be removed, cleaned, and its gap checked according to the service instructions within this Owner's Manual.
 - c. When cleaning, observe and obey the Warning within these Cleaning Instructions. This same Warning is also supplied on the heater.



WARNING

This heater must not be washed. Use of a pressure washer, water or liquid cleaning solution on this heater can cause severe personal injury or property damage due to water and/or cleaning solution:

- In electrical components, connections and wires causing electrical shock or component failure.
- On gas control valves causing corrosion which can result in gas leaks and fire or explosion from the leak.

This heater must be cleaned in accordance with the manufacturer's instructions without being subjected to liquid spray or wetting.

Maintenance Instructions

1. The area surrounding the heater shall be kept clear and free from combustible materials, gasoline, and other flammable vapors and liquids.
2. Regulators must be periodically inspected to make sure the regulator vents are not blocked. Debris, insects, insect nests, snow, or ice on a regulator can block vents and cause excess pressure at the heater.
3. Regulators can wear out and function improperly. Have your gas supplier check the date codes on all regulators installed and check delivery pressures to the heater to make sure that the regulator is reliable.
4. Check all wiring, associated terminals, and electrical components within the heater for corrosion, frayed or cut insulation, tight connections, etc. Repair or replace as necessary.
5. Review all heater markings (i.e. wiring diagram, warnings, start-up, shut-down, troubleshooting, etc.) at the time of maintenance for legibility. Make sure none are cut, torn, or otherwise damaged. Any damaged markings must be replaced immediately by contacting the L.B. White Co., Inc. Dataplates, start-up and shut-down instructions and warnings are available at no cost. A nominal charge will be applied for wiring diagrams.

Service Instructions

GENERAL

WARNING
Burn Hazard

- Heater surfaces are hot for a period of time after the heater has been shut down.
- Allow the heater to cool before performing service, maintenance, or cleaning.
- Failure to follow this warning will result in burns causing injury.

WARNING
Fire and Explosion Hazard

- Do not disassemble or attempt to repair any heater components or gas train components.
- All component parts must be replaced if defects are found.
- Failure to follow this warning will result in fire or explosions, causing property damage, injury, or death.

1. Close the fuel supply valve to the heater and disconnect the electrical supply before servicing unless necessary for your service procedure.
2. Open either panel for servicing of the heater's components.
3. Disconnect the appropriate electrical leads when servicing the heater's components.
4. For reassembly, reverse the respective service procedure. Ensure gas connections are tightened securely.
5. After servicing, start the heater to ensure proper operation and check for gas leaks.
6. Clean the heater's orifice with compressed air or a soft, dry rag. Do not use files, drills, broaches, etc. to clean the orifice hole. Doing so may enlarge the hole, causing combustion or ignition problems. Replace the orifice if it cannot be cleaned properly.

MOTOR AND FAN WHEEL

1. Remove screws securing motor mounting plate to housing.
2. Pull fan and motor assembly from housing.
3. Loosen set screws on fan wheel.
4. Pull fan wheel from motor shaft.
5. Remove the four nuts securing motor to mounting plate.

FIG. 12

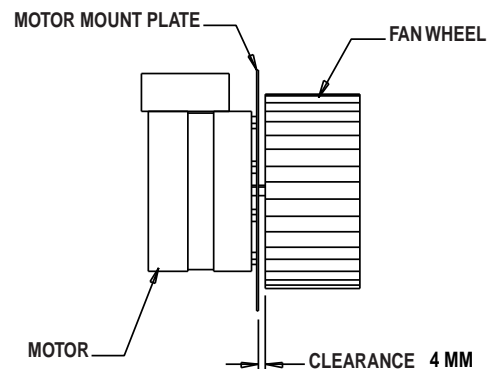

AIR PROVING SWITCH

1. Remove screws holding air proving switch blower housing.
2. Turn switch assembly 90 degrees so the switch paddle can be pulled through oblong hole on side of fan housing. See Fig. 13.
3. Disconnect the leads from the air proving switch.

FIG. 13

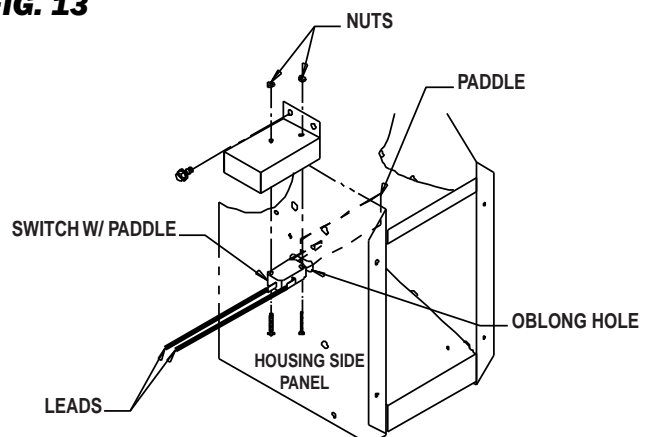

IGNITER AND FLAME SENSOR

IGNITER

1. Remove the screws securing the mounting bracket to the burner. See Fig. 14. Remove igniter assembly.
2. Disconnect igniter cable from igniter assembly.
3. Remove the screws securing the igniter to the mounting bracket.

■ The igniter and flame sensor should be cleaned to maintain proper ignition.

- Use steel wool or emery cloth.
- Rub briskly to remove buildup of dust, dirt, and oxide.

■ Check the component's insulative base for cracks.

- Replace the igniter if cracks are found.

FLAME SENSOR

1. Remove the screw securing the flame sensor to the mounting bracket. See Fig. 14.
2. Disconnect the flame sensor lead from the ignition control.

FIG. 14

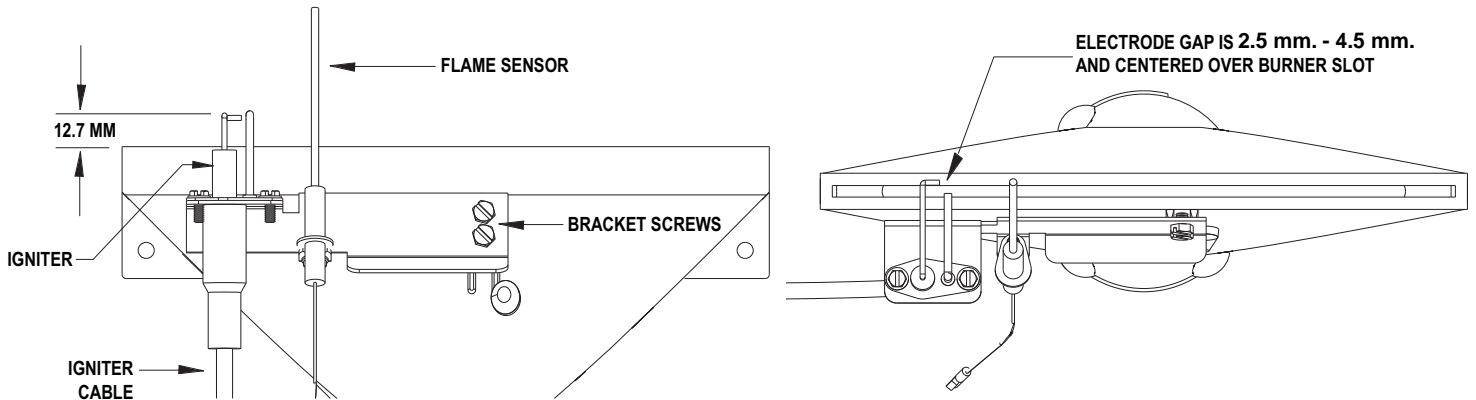

FUSE HOLDER AND FUSE

1. Refer to Fig. 15 for fuse removal.
2. Use only a 2 amp fuse rated for 250 volt - part # 571899. Do not substitute a fuse with a higher amp rating.

FIG. 15

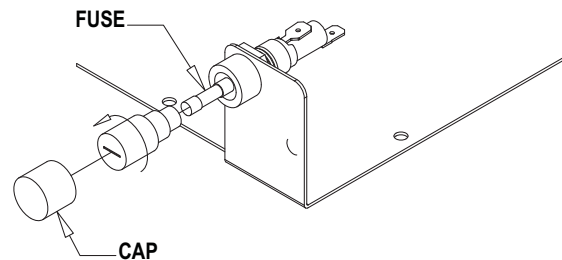



WARNING
Fire and Explosion Hazard

- Do not disassemble the gas control valve.
- Do not attempt to replace any components on the gas control valve.
- The gas control valve must be replaced if any physical damage occurs to the control valve assembly.
- Failure to follow this warning will result in fire or explosions, leading to injury or death to humans and livestock, and building damage.

ATTENTION

- The following explains a typical procedure to be followed in checking gas pressures.
- The gas pressures will vary depending upon country, gas category and fuel type.
- Consult the dataplate on the heater or pages 4 - 5 in this manual for specific pressures to be used in conjunction with this procedure.
- Gas pressure measured at the inlet to the gas valve is Inlet Pressure and gas pressure measured at the outlet of the gas valve is Burner Manifold Pressure.

A. Preparation

1. Obtain two pressure gauges capable of reading up to 65 mbar.
2. Disconnect the heater from the electrical supply and close the fuel supply valve to the heater inlet.
3. Open the burner access panel.
4. Brush or blow off any dust and dirt on or in the vicinity of the gas control valve.

B. Gauge Installation

1. Locate the inlet and outlet pressure taps, see Fig. 16. Turn screws internal to the pressure taps at least one full turn counterclockwise.
2. Securely connect a pressure gauge to each pressure tap.
3. Open the fuel supply valves to the heater and reconnect the heater electrical supply.
4. Start the heater.

C. Reading Pressures

1. With the heater operating, the pressure gauges should read the pressures specified on the dataplate.
2. Do the readings at the inlet and outlet pressure gauges agree with that specified on the dataplate? If so, then no further checking or adjustment is required. Proceed to Section D.
3. If the inlet pressures do not agree with that specified on the dataplate, then the building system regulator controlling gas pressure to the heaters requires adjustment.
4. If the inlet pressures are correct and the burner manifold pressure does not agree with that specified on the dataplate, then the gas control valve's internal pressure regulator requires adjustment. See Fig. 17 for regulator location.

D. Completion

1. Once inlet and burner manifold pressures have been confirmed and/or properly set, close the fuel supply valve to the heater and allow the heater to burn off any gas remaining in the gas supply line.
2. Disconnect the heater from its electrical supply.
3. Remove the gauges and connecting hoses.
4. Tighten the pressure tap screws by turning clockwise. Check for gas leaks to insure the tap screws have seated properly.

FIG. 16

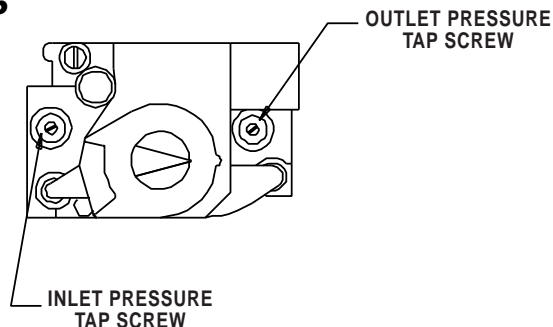
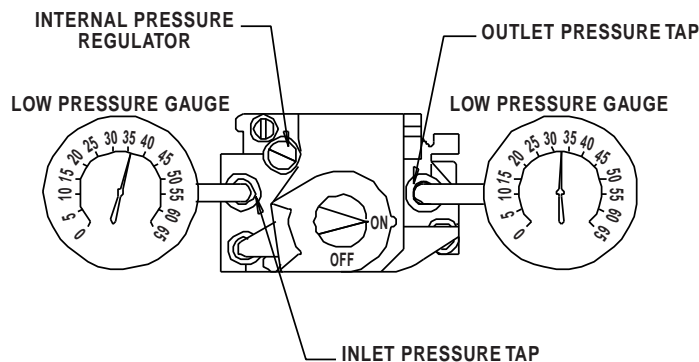

FIG. 17



TESTING THE MANUAL RESET HIGH LIMIT SWITCHES

WARNING
Fire Hazard

- Do not operate the heater with the high limit switch bypassed.
- Operating the heater bypassed high limit switch may lead to overheating, possibly resulting in a fire, with subsequent damage to the heater or property damage.

This heater has two limit switches, One on the heat chamber, the other on the fan housing. Both switches should be tested annually, typically when the heater is given a thorough cleaning.

1. Remove either high limit switch.
2. Holding the switch by one of its mounting legs, apply a small flame only to the sensing portion on the back of the switch. Be careful not to melt the plastic housing of the switch when conducting this test.
3. Within a minute, you should hear a pop coming from the switch, indicating the contacts of the switch have opened.

4. Allow the switch cool down for about a minute before firmly pressing the reset button on the switch.
5. Check for electrical continuity across the switch terminals to make sure the contacts have closed.

FIG. 18

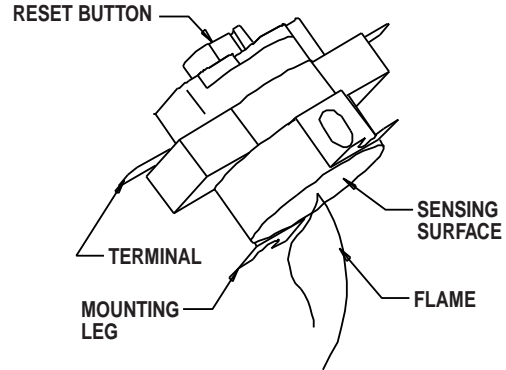

BURNER ORIFICE AND GAS CONTROL VALVE

1. Remove gas hose from heater.
2. Remove the elbow and screws at inlet of gas control valve. See Fig. 19.

FIG. 19

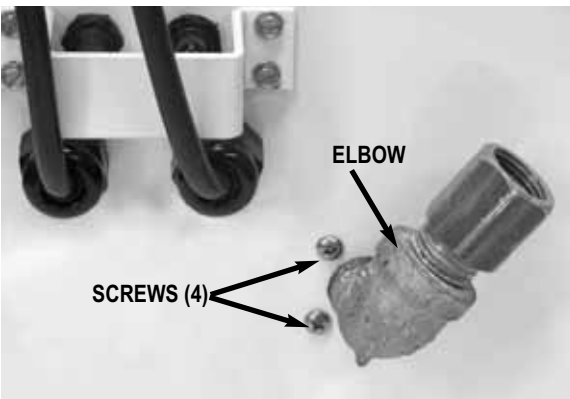

3. Disconnect gas control valve's electrical leads.
4. Use a ratchet with extension and 9/16 in. socket to remove burner retaining bolt at underside of heater's base. The bolt is accessible through the slot in heater's support leg.
5. Pivot the gas control assembly to expose burner orifice. See Fig. 20. Replace components as needed.

FIG. 20

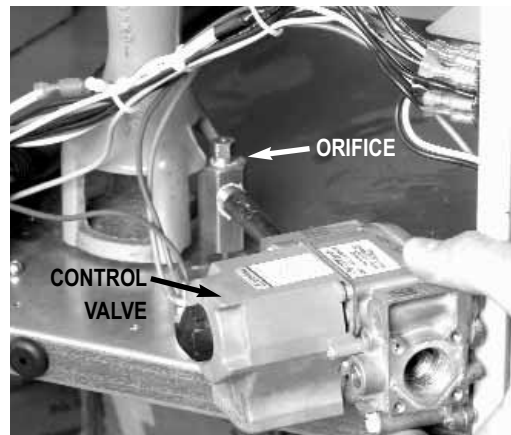

6. When assembling valve to manifold, ensure valve is offset 8 degrees from the orifice holder. See Fig. 21.

FIG. 21

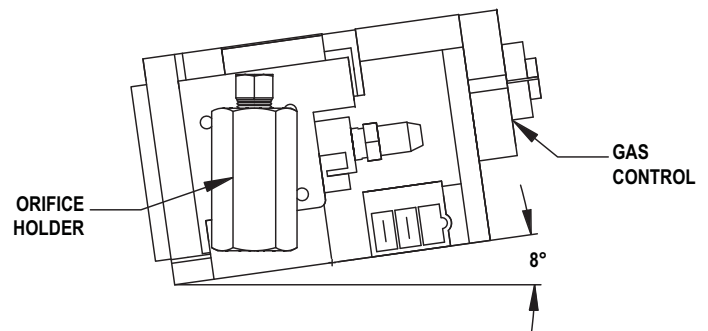

 **WARNING**
Electrical Shock and Burn Hazard

- Troubleshooting this system may require operating the unit with line voltage present and gas on. Use extreme caution when working on the heater.
- Failure to follow this warning may result in property damage, personal injury or death.

READ THIS ENTIRE SECTION BEFORE BEGINNING TO TROUBLESHOOT PROBLEMS.

The following troubleshooting flow charts provide systematic procedures for isolating equipment problems. The charts are intended for use by a QUALIFIED GAS HEATER SERVICE PERSON. **DO NOT SERVICE THESE HEATERS UNLESS YOU HAVE BEEN PROPERLY TRAINED.**

TEST EQUIPMENT REQUIRED

The following pieces of test equipment will be required to troubleshoot this system.

- **Digital Multimeter** - for measuring AC and DC voltage and resistance.
- **Low Pressure Gauge** - for checking inlet and outlet pressures of the gas control valve against dataplate rating.

INITIAL PREPARATION

- Visually inspect equipment for apparent damage.
- Check all wiring for loose connections and worn insulation.

Refer to the system operation sequence in this section to understand how the heater operates during a call for heat.

If the heater is not operational, push and release the reset switch to restart the heater. Observe heater operation. Identify the problem and refer to the appropriate troubleshooting flow charts for problem solving. Perform all troubleshooting steps identified by the flow charts.

<u>Heating Mode Problems</u>	<u>Page</u>
Fan motor does not run, heater does not light.	22
Fan motor runs, igniter does not spark.	23
Fan motor runs, igniter sparks, but heater does not light	24
Heater lights, but does not stay lit	25

<u>Ventilation Mode Problems</u>	<u>Page</u>
Motor does not run	25
Motor runs slowly.	25

Components should be replaced only after each step within the flow chart has been completed and replacement is suggested in the flow chart. Refer to the Servicing sections as necessary to obtain information on disassembly and replacement procedures of the component. Verify proper heater operation after servicing.

DIRECT IGNITION OPERATION SEQUENCE:

- Line voltage is supplied to selector switch.
- Selector switch is set to HEAT.
- Line voltage is supplied to motor relay, ignition control and thermostat from selector switch.
- A call for heat occurs from the thermostat.
- Thermostat contacts close.
- Ignition control performs self safety check
 - Internal components are tested
 - Air proving circuit is checked
- Ignition control sends line voltage to motor relay.
 - Relay contacts close
 - Relay sends power to fan motor
 - Fan motor starts
- Ignition control sends line voltage to air proving switch.
 - Air proving switch contacts close on an increase in air pressure.
- Ignition control begins ignition trial sequence.
- Ignition control sends line voltage to transformer.
- Transformer reduces line voltage to 24 volts.
 - 24 volts is sent to fuse.
 - Fuse sends 24 volts to high limit switches.
 - High limits send 24 volts to gas control valve.
 - Gas control valve opens.
- Ignition control sends high voltage to igniter electrode.
 - Igniter sparks.
 - Ignition occurs.
- Igniter continues to spark until flame proving occurs.
 - Ignition spark is shut off.
 - Gas control valve stays open.
- Room warms to desired temperature.
 - Thermostat is satisfied, thermostat contacts open.
 - Heater shuts down.
- Process begins again on a call for heat.

IGNITION FAILURE SEQUENCE:

- There are three trials for ignition. Each trial for ignition takes approximately 15 seconds
- If ignition is not maintained, the ignition control shuts the heater down.
 - Gas valve closes
 - Ignition spark is discontinued
 - Fan motor stops
- **To retry for ignition, push and hold the reset switch for at least 3 seconds and until fan motor restarts.**

HEATING MODE

Problem

Fan Motor Does Not Run, Heater Does Not Light.

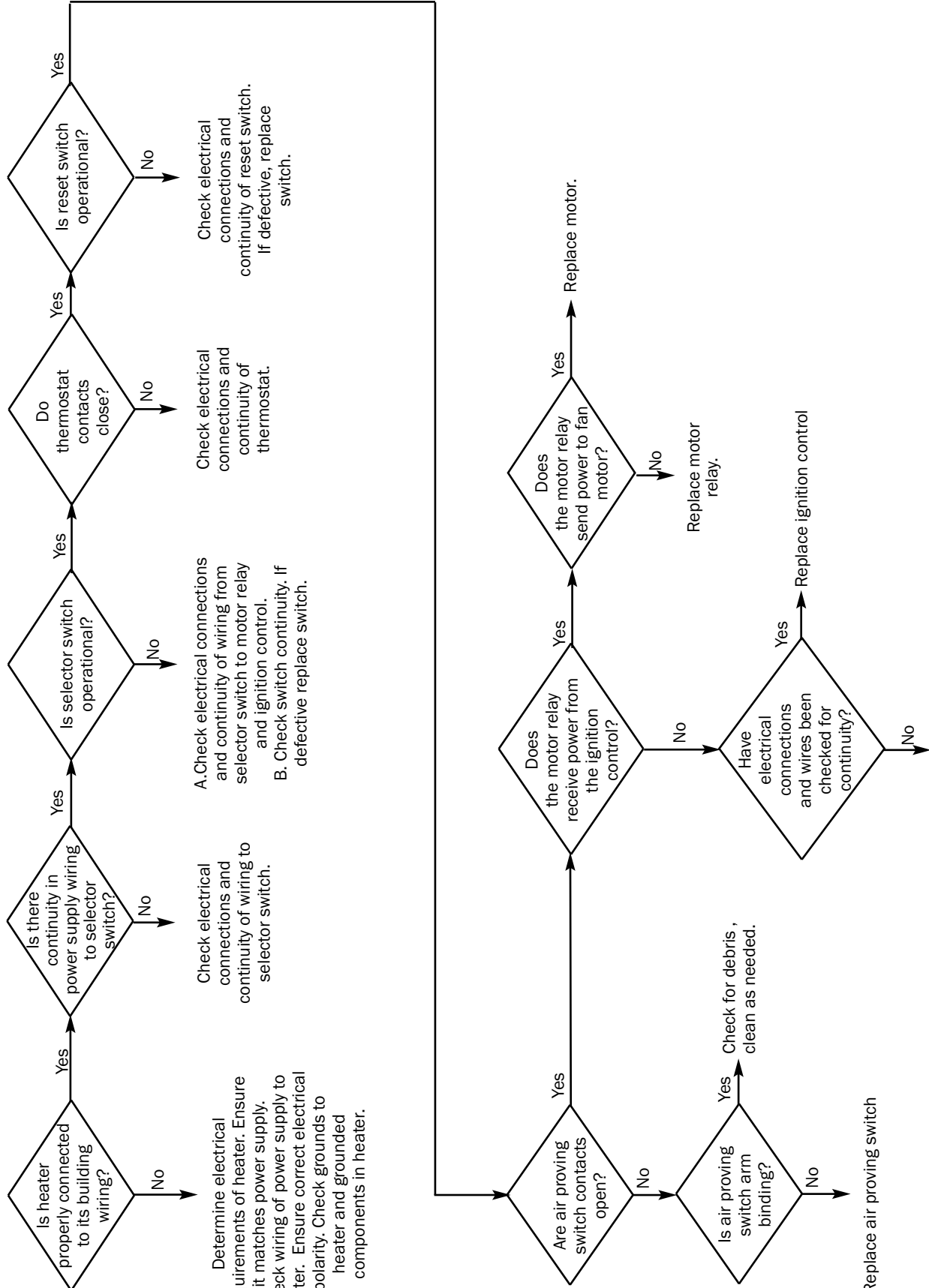

Problem
Fan Motor
Runs Igniter
Does Not
Spark.

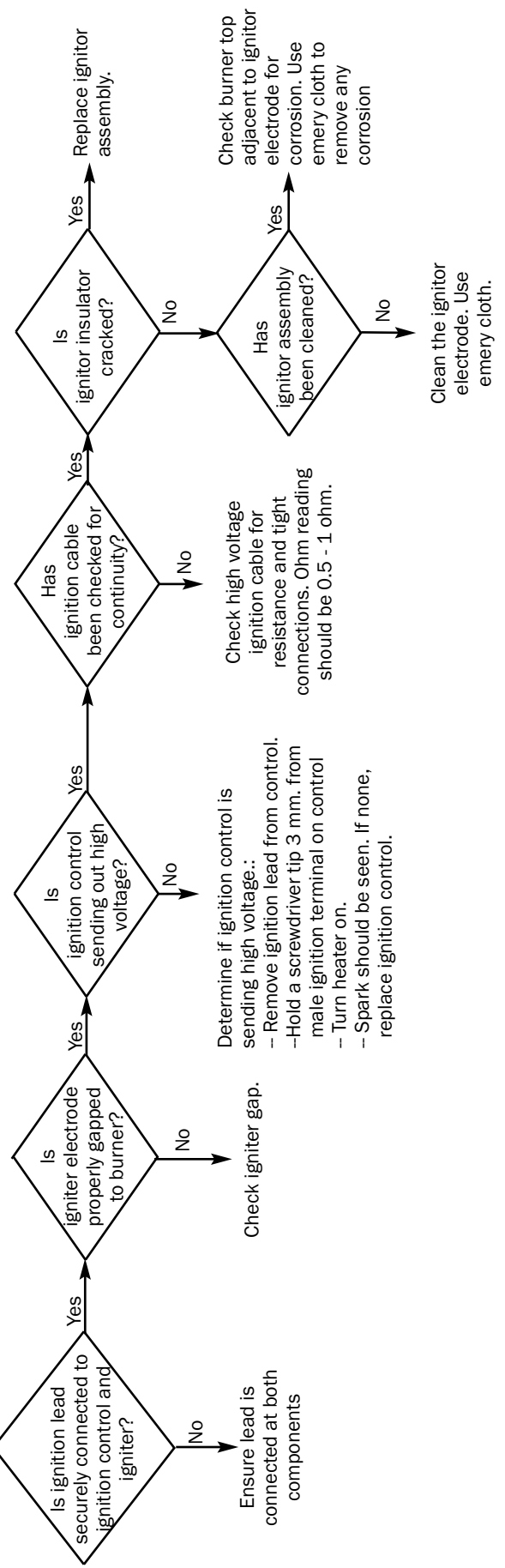
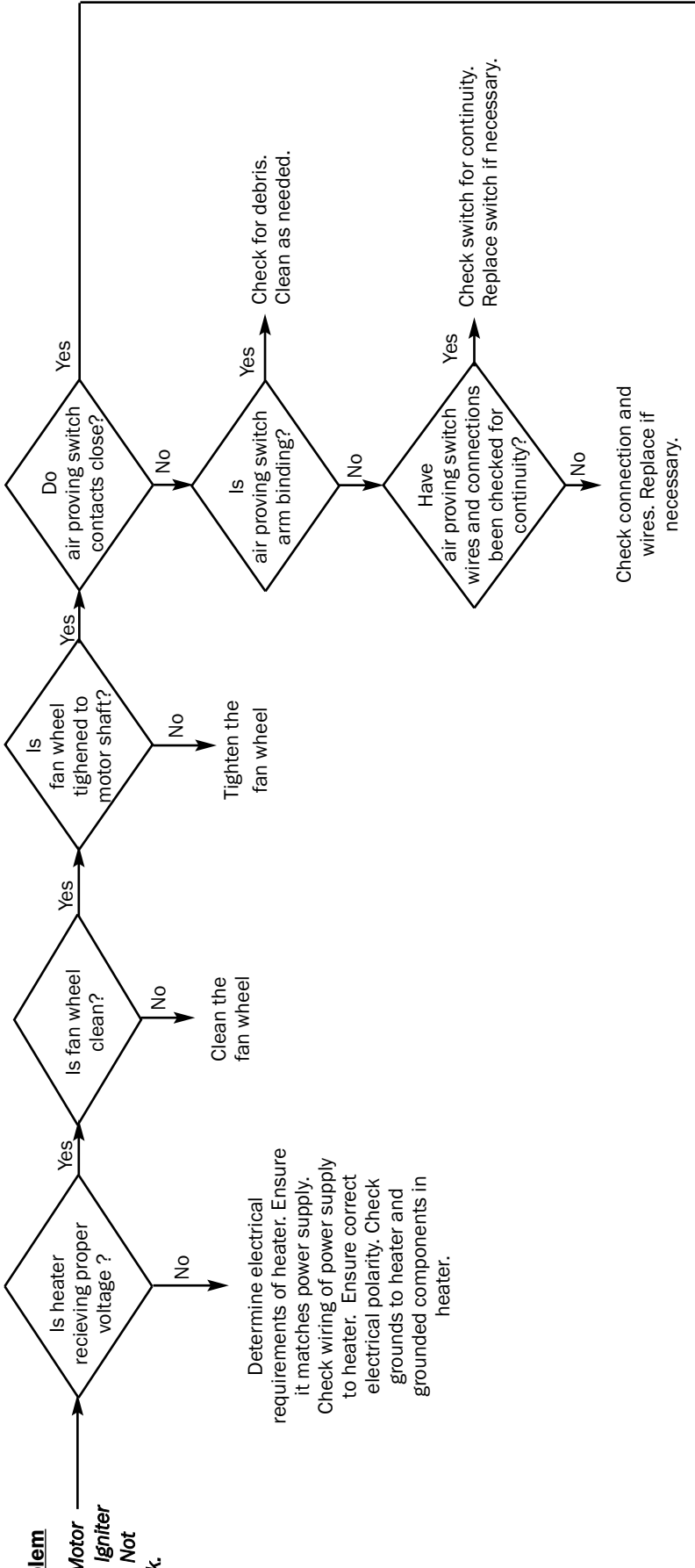

Problem

**Fan Motor
Runs, Igniter
Sparks, Heater
Does not Light.**

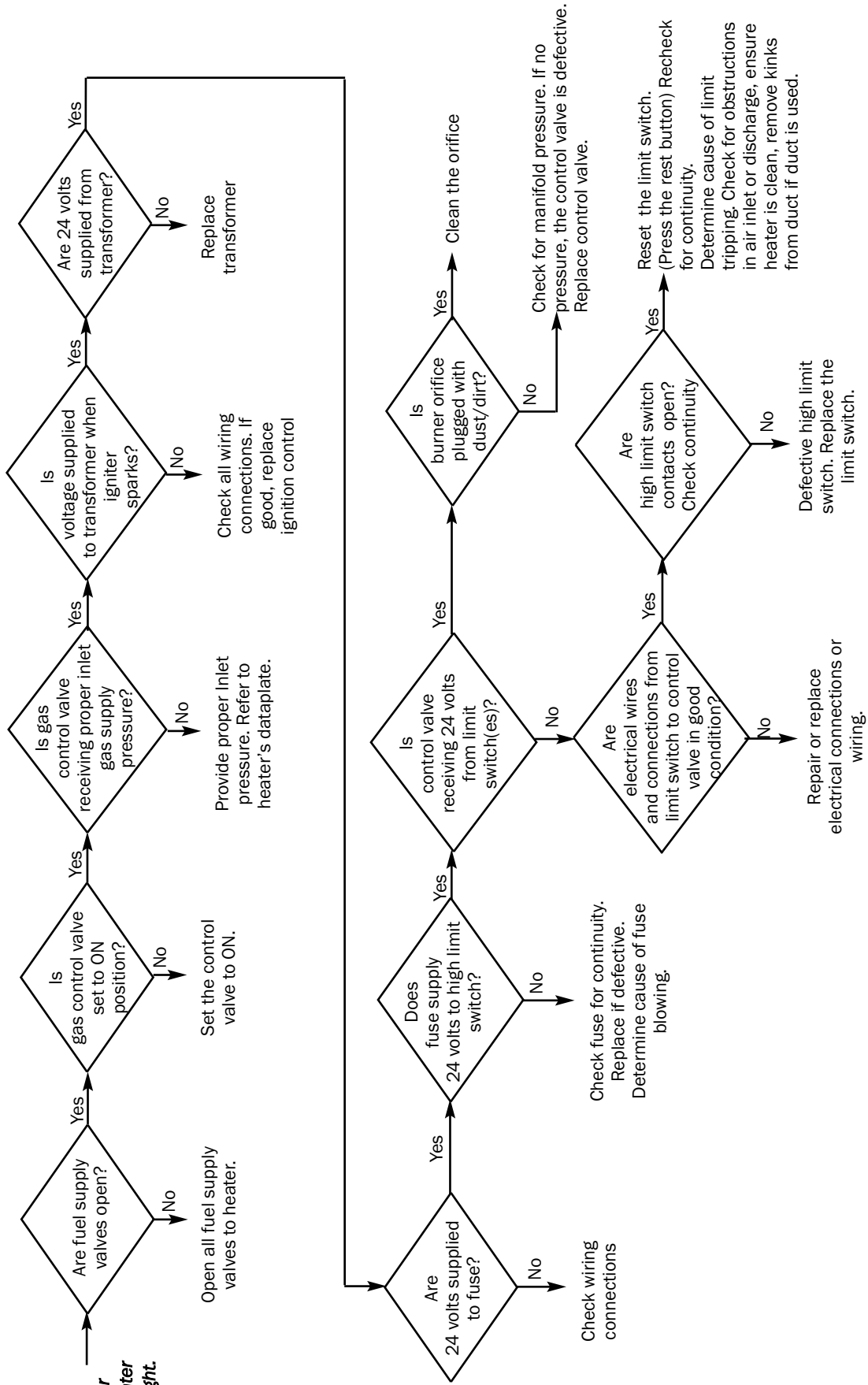

Problem

Heater Lights, But Doesn't Stay Lit.

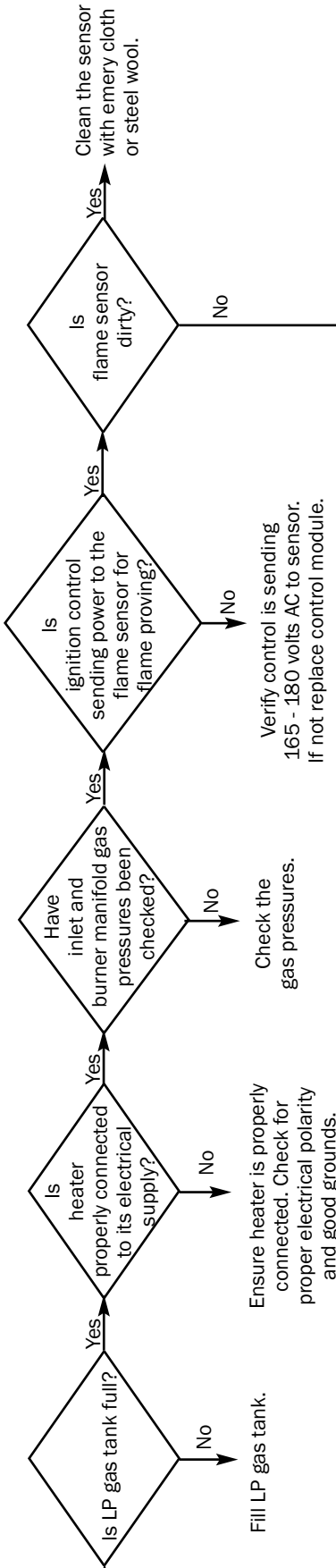

VENTILATION MODE

Problem

Motor Does Not Run

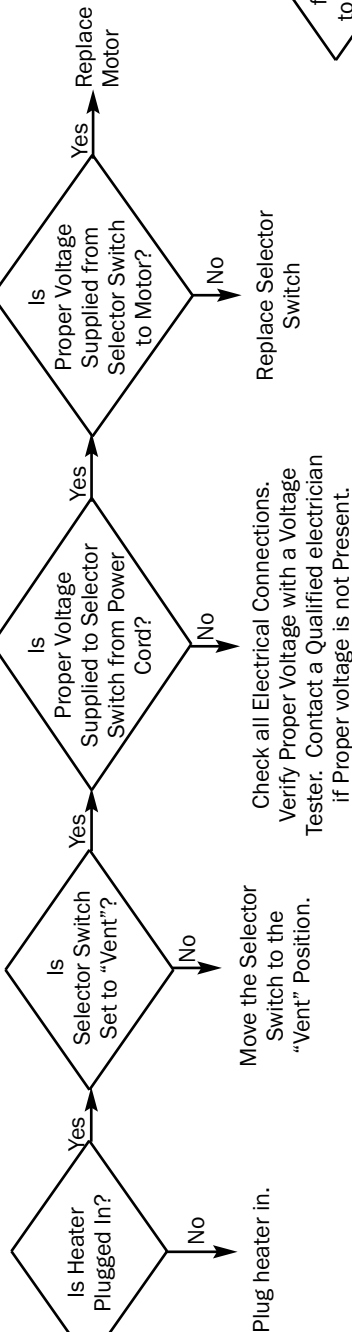

Problem

Motor "Hums". Does Not Run.

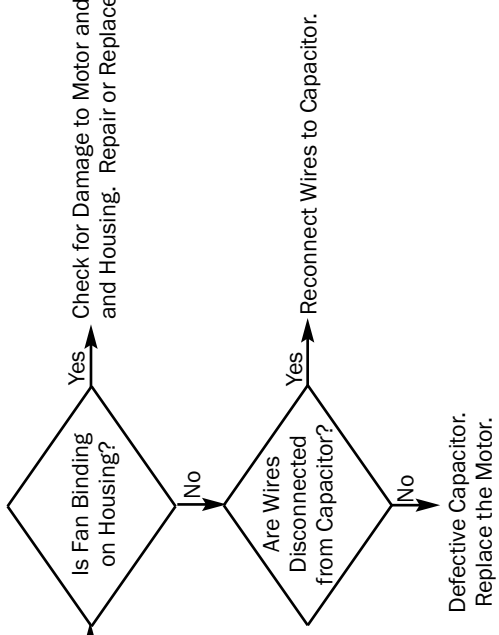

NOTES:

- (1) With any electrical problem, all wiring should be checked for good connections and proper voltage.
- (2) The ignition control module sends and receives voltages throughout the entire operation sequence. The ignition control module terminals should also be checked for delivering proper voltages in addition to the individual components to make sure the board itself is working properly.
- (3) The high limit switch will activate for a number of reasons. Common problems associated with this are high gas pressure, low voltage, loose or dirty fans, restrictions/blockages at air inlets or outlets, or excessive dust and dirt accumulations in the heater.

Electrical Connection and Ladder Diagram

CAUTION - REFER TO THE HEATER'S ELECTRICAL CONNECTION DIAGRAM WHEN SERVICING THE HEATER'S ELECTRICAL COMPONENTS TO AVOID WIRING ERRORS & EQUIPMENT MALFUNCTION.
CHECK FOR PROPER OPERATION AFTER SERVICING.

WARNING: THIS HEATER MAY START AT ANY TIME

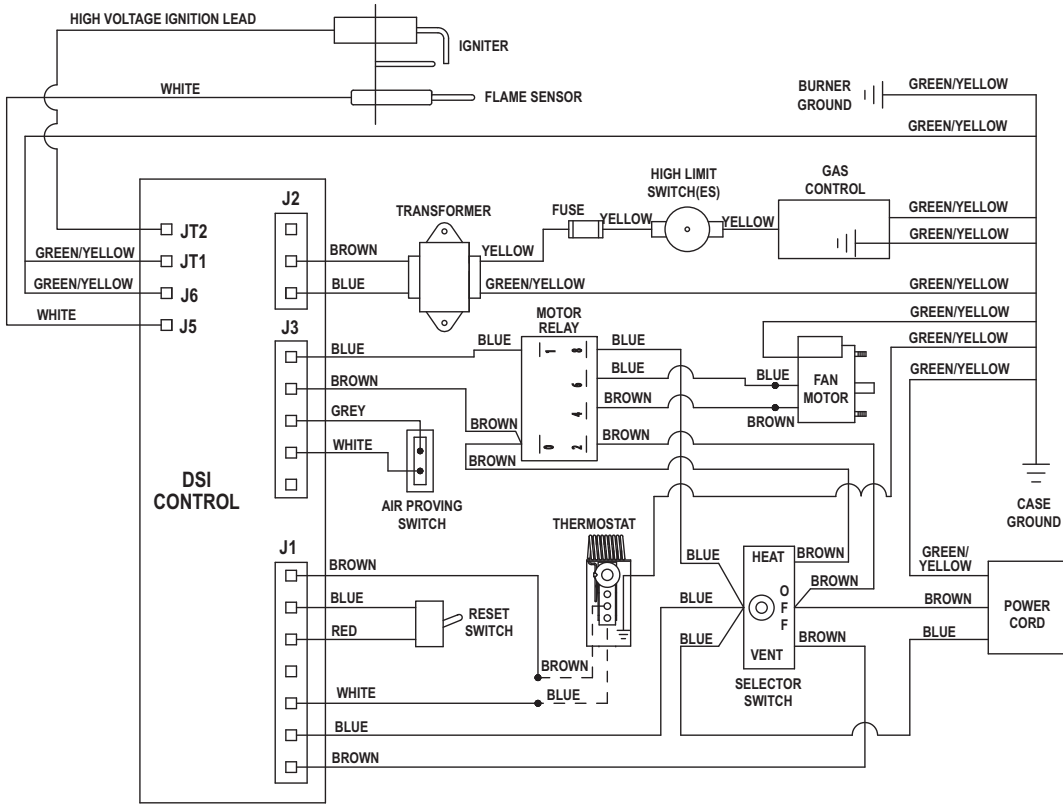

ELECTRICAL CONNECTION DIAGRAM

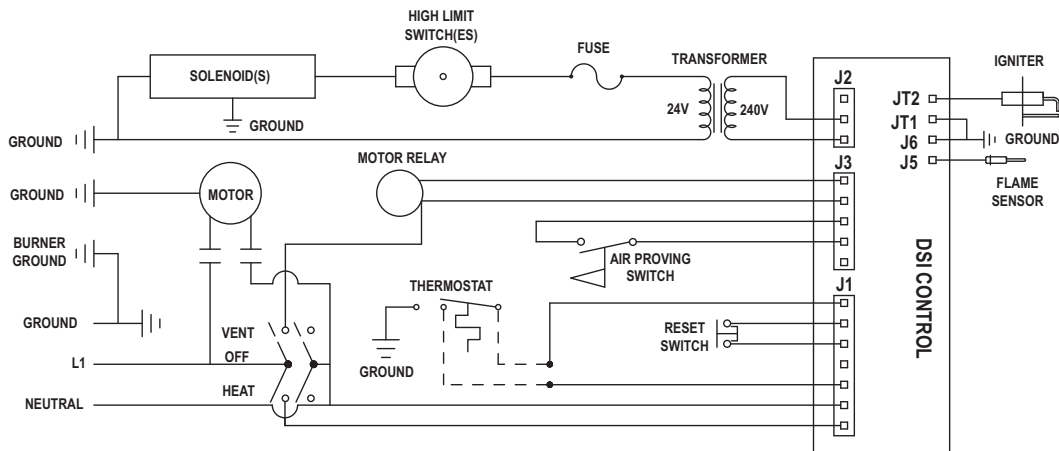

ELECTRICAL LADDER DIAGRAM

IF ANY OF THE ORIGINAL WIRE AS SUPPLIED WITH THE HEATER MUST BE REPLACED, IT MUST BE REPLACED WITH WIRING MATERIAL HAVING A TEMPERATURE RATING OF AT LEAST 302°F (150°C)

Heater Component Function

Air Proving Switch with Paddle

Safety device used to insure that the proper air flow is being achieved before the gas valve is opened.

Burner

Cast iron component used to mix air and gas and provide an area at which the fuel may ignite.

Burner Orifice

Brass metering device used to supply gas to burner at a specific rate.

Direct Spark Ignition Control Module

Electronic printed circuit board which sends and receives voltages to various controls in an automatic ignition system. An important safety feature of the control board is that it will shut down the entire heater, thereby stopping the flow of fuel gas if burner flame goes out.

Fan Housing

Chamber used for delivering air for efficient air movement.

Fan Wheel

Component used in conjunction with the motor and fan housing to pull the hot air from heater and blow it into room for heating (also known as a squirrel cage).

Flame Sensor

Also known as a flame rod or flame probe, this part works with the ignition control in proving that burner flame has been established.

Fuse

Safety device which is used to protect against an over amperage condition which results from a direct electrical short or an overload condition within the 24 volt circuit.

Gas Control Valve

Electrical device consisting of a low pressure regulator and electrical solenoids used for the control of gas flow to the burner assembly. A feature of the control valve is a built-in gas shut off which may be used to isolate the heater from its gas supply when servicing.

Gas Hose

Flexible connector used to deliver gas from supply line in building to heater.

Heat Chamber

Metal fire box that provides an area where burner flame mixes with combustion air thereby providing heat.

High Limit Switch

Safety device wired into the control system which is used to break an electrical circuit to the gas control valve in event of overheat situation.

Igniter

Ignition device used on automatic direct spark ignition control systems. Ignites gas by spark.

Motor

Electric device used to drive a fan to pull preheated air through the heater and to circulate heat within a certain area. Converts electrical energy into mechanical energy.

Motor Relay

Electrical component wired between ignition control and motor. Used to feed voltage to motor upon receipt of voltage from ignition control.

Regulator

Mechanical device used in L.P. and natural gas distribution systems to reduce a higher inlet pressure to a preset lower pressure. The regulator is responsible to supply a steady outlet pressure to the heater(s) despite changes in inlet pressure, heater demand and weather conditions.

Reset Switch

Electrical component used for resetting the ignition control module and restart the heater if a problem occurs.

Selector Switch

Electrical device which is used to allow the end user to use the heater in either a heating or ventilation application.

Thermostat

Electrical device used as an automatic on/off switch which will respond to changes in temperature in a certain area. Can be wired so contacts in the thermostat open or close on temperature increase or decrease.

Transformer

Electrical control used to accept line power supply primary voltage and reduce it to lower secondary voltage to operate certain control systems.

PARTS SCHEMATIC

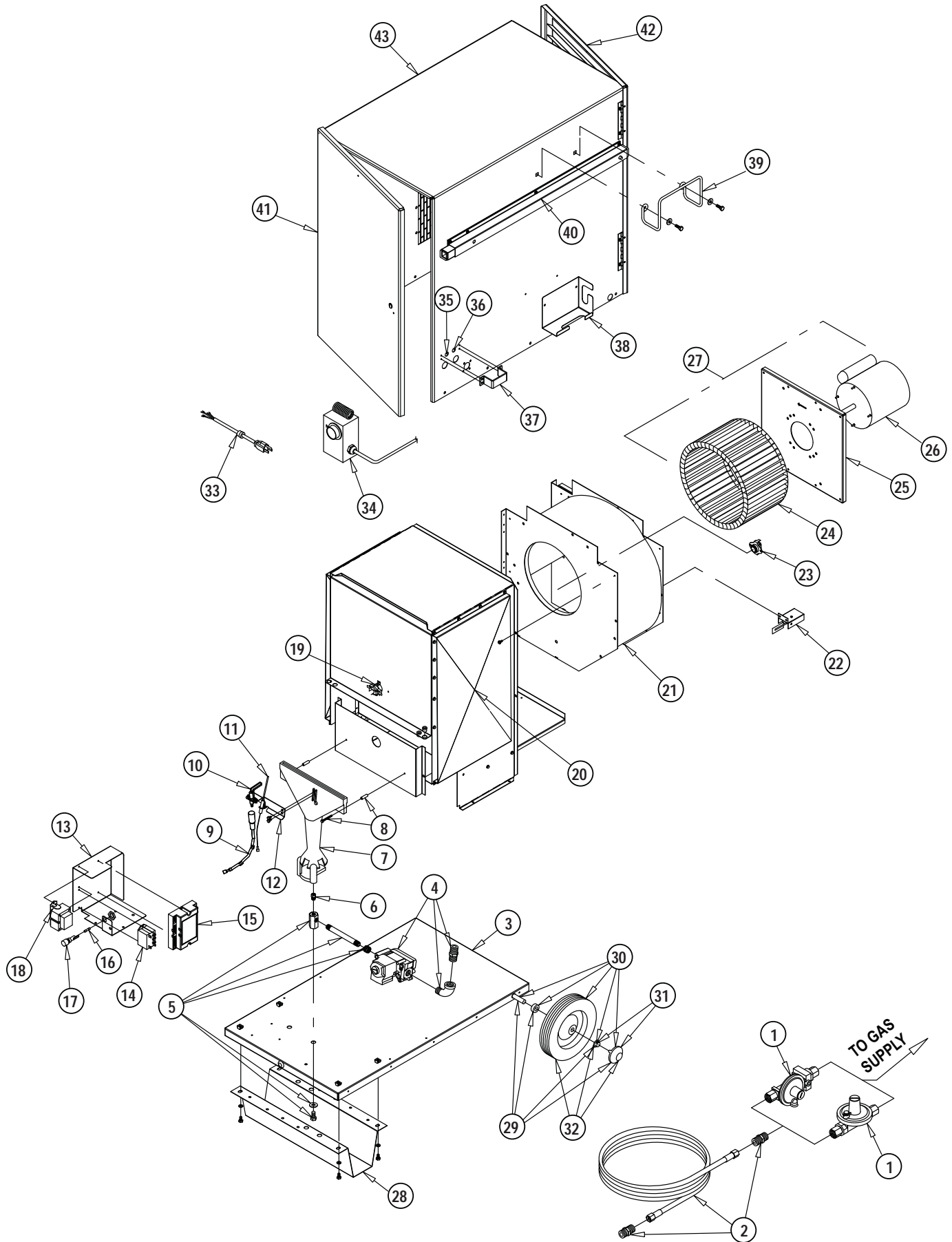

PARTS LIST

Item	Description		Part Number
1	Regulator, Propane Gas, 1/4 BSPT Inlet	Propane Gas	23042
	Regulator, Natural Gas 1/2 BSPT Inlet x 1/2 BSPT Outlet	Natural Gas	23043
2	Hose, 12.7 mm ID x 3 m w/ 1/2 BSPT Male x M20 x 1.5 Male Adapters		21555
3	Base		571891
4	Valve, Gas Control	Propane Gas	571892
		Natural Gas	571893
5	Manifold w/ Hardware		571894
6	Orifice, Burner	Propane Gas	571623
		Natural Gas	571895
7	Burner		571815
8	Burner Mounting Hardware		570211
9	Wire, Ignition		571915
10	Spark Electrode		571662
11	Flame Sensor		571896
12	Bracket, Electrode		571897
13	Bracket, Electrical Components		571898
14	Relay, Motor		571916
15	Control, Ignition		25516
16	Fuse, 2 Amp / 250 Volt		571899
17	Fuse Assembly		21681
18	Transformer		571900
19	Switch, High Limit, Burner End		571664
20	Chamber, Heat		571901
21	Fan Housing Assembly w/ Air Proving Switch, High Limit Switch, and Motor Mount		571775
22	Air Proving Switch Assembly		571299
23	Switch, High Limit, Fan End		571400
24	Fan Wheel		570481
25	Motor Mount		570251
26	Motor, Ball Bearing		571902
27	Fan Wheel Assembly, w/ Motor and Mount		571903
28	Leg,		571795
29	Axle		571790
30	Wheels and Axle		571800
31	Caps		571110
32	Wheel		571904
33	Power Cord		571905
34	Thermostat with Cord		20057
35	Selector Switch w/ Boot		571906
36	Reset Switch w/ Boot		571907
37	Switch Guard		571908
38	Bracket, Regulator Storage		571909
39	Bracket, Hose Storage		571619
40	Handles, Extending		571760
41	Door, Burner End, w/ Hinges and Latch	Propane Gas	571910
		Natural Gas	571911
42	Door, Fan End, w/ Hinges and Latch		571912
43	Case Assembly w/ Hardware	Propane Gas	571913
		Natural Gas	571914

Warranty Policy

EQUIPMENT

L.B. White Co., Inc. warrants that the component parts of its equipment are free from defects in material and workmanship, when properly installed, operated, and maintained in accordance with the Installation and Maintenance Instructions, safety guides and labels contained with each unit. If, **within 12 months from the date of purchase by the end user**, any component is found to be defective, L.B. White Co., Inc. will at its option, repair or replace the defective part or equipment, with a new part or equipment, F.O.B., Onalaska, Wisconsin.

A warranty card on file at L.B. White will automatically qualify a unit and its component parts for warranty consideration. If a warranty card is not on file, a copy of the bill of sale will be required to establish warranty qualification. If neither is available, the warranty period will be 12 months from date of shipment from L B. White.

PARTS

L.B. White Co., Inc. warrants that replacement parts purchased from the company and used on the appropriate L. B. White equipment are free from defects both in material and workmanship for **12 months from the date of purchase by the end user**. Warranty is automatic if a component is found defective within 12 months of the date code marked on the part. If the defect occurs more than 12 months later than the date code but within 12 months from the date of purchase by the end user, a copy of a bill of sale will be required to establish warranty qualification.

duration to the duration of the applicable warranty stated above. The remedies set forth above are the sole and exclusive remedies available hereunder. L.B. White will not be liable for any incidental or consequential damages directly or indirectly related to the sale, handling or use of the equipment, and in any event L.B. White's liability in connection with the equipment, including for claims based on negligence or strict liability, is limited to the purchase price.

The warranty set forth above is the exclusive warranty provided by L.B. White, and all other warranties, including any implied warranties or merchantability or fitness for a particular purpose, are expressly disclaimed. In the event any implied warranty is not hereby effectively disclaimed due to operation of law, such implied warranty is limited in

Some regions do not allow limitations on how long an implied warranty lasts, so the above limitation may not apply to you. Some regions do not allow the exclusion or limitation of incidental or consequential damages, so the above limitation or exclusion may not apply to you. This warranty gives you specific legal rights, and you may also have other rights which vary from region to region.

Replacement Parts and Service

Contact your local L.B. White dealer for replacement parts and service or call the L.B. White Company, Inc. at 1-608-783-5691 for assistance. Be sure that you have your heater model number and configuration number when calling.